

grensan®



DAISO
TOTAL PLANNING

ÜRÜN KATALOĐU

HAZIR OLUKLAR

1984 yılındaki ilk tanıtımından sonra dünya çapında büyük ilgi görmüştür. İyi koşullar altında 300.000 baskıya kadar sorunsuz çalışır. Bazı karton işlerinde 500.000-600.000 baskı almak mümkündür. Standart 150 çeşit ölçü üretiminden seçim yapabilirsiniz veya isteğe bağlı üretim yapılabilmektedir. G-Tape, çevreye duyarlı yandığında zehirli gaz ihtiva etmeyen ürüne sahiptir. Bunun yanı sıra kesim süresince oluşan statik elektrik problemlerini ortadan kaldırır, iletken olmayan bir üründür.



A type (Karton / Oluklu Mukavva)

Kod	Kalınlık	Genişlik
A-0308	0.3	0.8
A-0408	0.4	0.8
A-0410	0.4	1.0
A-0411	0.4	1.1
A-0412	0.4	1.2
A-0413	0.4	1.3
A-0414	0.4	1.4
A-0415	0.4	1.5
A-0416	0.4	1.6
A-0417	0.4	1.7
A-0419	0.4	1.9
A-0513	0.5	1.3
A-0514	0.5	1.4
A-0515	0.5	1.5
A-0516	0.5	1.6
A-0517	0.5	1.7
A-0518	0.5	1.8
A-0519	0.5	1.9
A-0520	0.5	2.0
A-0521	0.5	2.1
A-0522	0.5	2.2
A-0524	0.5	2.4
A-0617	0.6	1.7
A-0619	0.6	1.9
A-0620	0.6	2.0
A-0621	0.6	2.1
A-0622	0.6	2.2
A-0623	0.6	2.3
A-0624	0.6	2.4
A-0625	0.6	2.5
A-0627	0.6	2.7
A-0630	0.6	3.0
A-0715	0.7	1.5
A-0717	0.7	1.7
A-0719	0.7	1.9
A-0720	0.7	2.0
A-0721	0.7	2.1
A-0722	0.7	2.2
A-0825	0.8	2.5
A-0827	0.8	2.7
A-0830	0.8	3.0

B type (Oluklu Mukavva)

Kod	Kalınlık	Genişlik
B-0622	0.6	2.2
B-0624	0.6	2.4
B-0627	0.6	2.7
B-0630	0.6	3.0
B-0632	0.6	3.2
B-0635	0.6	3.5
B-0640	0.6	4.0
B-0645	0.6	4.5
B-0650	0.6	5.0
B-0725	0.7	2.5
B-0727	0.7	2.7
B-07B0	0.7	3.0
B-0732	0.7	3.2
B-0735	0.7	3.5
B-0827	0.8	2.7
B-0830	0.8	3.0
B-0832	0.8	3.2
B-0835	0.8	3.5
B-0840	0.8	4.0
B-0845	0.8	4.5
B-0850	0.8	5.0
B-0860	0.8	6.0
B-1030	1.0	3.0
B-1032	1.0	3.2
B-1035	1.0	3.5
B-1040	1.0	4.0
B-1045	1.0	4.5
B-1050	1.0	5.0
B-1060	1.0	6.0

S type (Karton / Oluklu Mukavva)

Kod	Kalınlık	Genişlik
S-0627	0.6	2.7
S-0630	0.6	3.0
S-0632	0.6	3.2
S-0827	0.8	2.7
S-0830	0.8	3.0
S-0832	0.8	3.2

- Uzunluk 700mm
- Pilyaj Bıçağı : 2-3pt(0.7-1.0mm)



M type (Oluklu Mukavva)

Kod	Kalınlık	Genişlik
M-0408	0.4	0.8
M-0410	0.4	1.0
M-0411	0.4	1.1
M-0412	0.4	1.2
M-0413	0.4	1.3
M-0414	0.4	1.4
M-0415	0.4	1.5
M-0416	0.4	1.6
M-0417	0.4	1.7
M-0419	0.4	1.9
M-0513	0.5	1.3
M-0514	0.5	1.4
M-0515	0.5	1.5
M-0516	0.5	1.6
M-0517	0.5	1.7
M-0518	0.5	1.8
M-0519	0.5	1.9
M-0520	0.5	2.0

- Uzunluk 700mm
- Pilyaj Bıçağı : 2-3pt(0.7-1.0mm)

- Uzunluk 700mm
- Pilyaj Bıçağı: 4pt(1.4mm)

M•A•B•S•C•D type

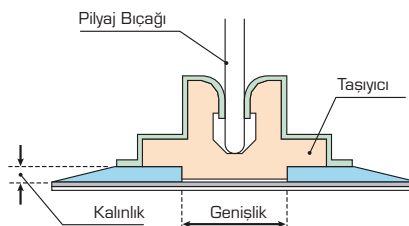

- Uzunluk 700mm
- Pilyaj Bıçağı: 2-3pt(0.7-1.0mm)

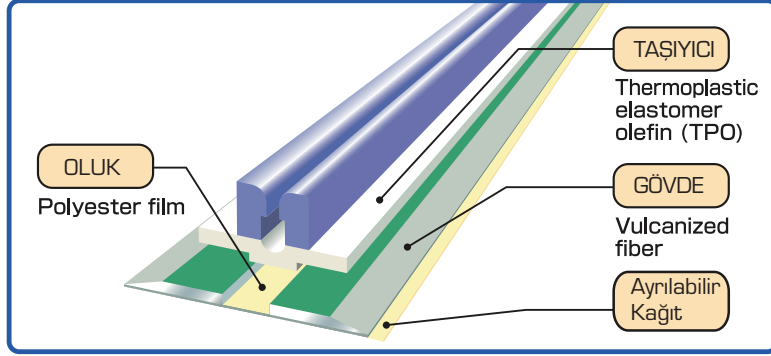

Volkanik Fiber Nedir ?

Safılık oranı yüksek selülozun bir çok katman halinde jelatin kıvamına getirilmesiyle üretilen bir malzemedir. Bu yapının içerisindeki liflerin birbirine çok sıkı tutunması nedeniyle baskı ve ezilmelere karşı çok dayanıklıdır.



Genişlik
15mm



Genişlik
15mm



Genişlik
15mm

C type (Oluklu Mukavva)		
Kod	Kalınlık	Genişlik
C-0640	0.6	4.0
C-0832	0.8	3.2
C-0835	0.8	3.5
C-0840	0.8	4.0
C-0845	0.8	4.5
C-0850	0.8	5.0
C-0860	0.8	6.0
C-1040	1.0	4.0
C-1045	1.0	4.5
C-1050	1.0	5.0
C-1060	1.0	6.0

•Uzunluk 700mm
•Pilyaj Bıçağı : 6pt(2.0mm)

D type (Oluklu Mukavva)		
Kod	Kalınlık	Genişlik
D-0850	0.8	5.0
D-0860	0.8	6.0
D-0870	0.8	7.0
D-1050	1.0	5.0
D-1055	1.0	5.5
D-1060	1.0	6.0
D-1070	1.0	7.0

•Uzunluk 700mm
•Pilyaj Bıçağı : 8pt(3.0mm)

G type (Ters Oluk)			
Kod	Kalınlık	Width	Genişlik
G-1	0.6	0.7	1.7
G-2	0.8	1.0	2.4
G-3	1.0	1.5	3.0
G-4	1.0	2.0	4.0
G-5	1.0	3.0	5.0
G-6	1.0	3.0	6.0

•Genişlik 15mm (yalnız G-1 10mm)
•Uzunluk 700mm

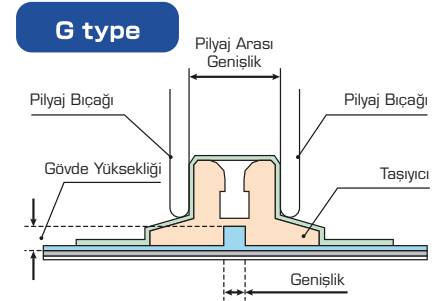

HAZIR OLUKLAR



W type			
Kod	Kalınlık	Genişlik	Pilyaj Bıçağı
W-0410	0.4	1.0	2-3pt (0.7-1.0mm)
W-0413	0.4	1.3	
W-0415	0.4	1.5	
W-0417	0.4	1.7	
W-0515	0.5	1.5	
W-0517	0.5	1.7	
W-0519	0.5	1.9	
★W-0521	0.5	2.1	
W-0523	0.5	2.3	
W-0615	0.6	1.5	
W-0617	0.6	1.7	
W-0619	0.6	1.9	
W-0621	0.6	2.1	
W-0624	0.6	2.4	
W-0824	0.8	2.4	
W-0827	0.8	2.7	
W-0830	0.8	3.0	
WL-0622	0.6	2.2	4pt (1.4mm)
WL-0624	0.6	2.4	
WL-0627	0.6	2.7	
WL-0630	0.6	3.0	
★WL-0824	0.8	2.4	
★WL-0827	0.8	2.7	
WL-0830	0.8	3.0	

(Çiftli Pilyaj)
•Uzunluk 700mm



KW type					
Kod	Kalınlık	Genişlik	Merkez Aralığı	Pilyaj Bıçağı	Merkez
★KW01	0.6	3.0	6.0	4pt (1.4mm)	0.6x3.0
★KW02	0.6	3.0	7.0		0.6x4.0
★KW03	0.6	3.0	8.0		0.6x5.0
★KW04	0.8	3.2	6.0		0.4x3.0
★KW05	0.8	3.2	7.0		0.4x4.0
★KW06	0.8	3.2	8.0		0.4x5.0



1W type		
Kod	Kalınlık	Genişlik
★1W-0414	0.4	1.4
★1W-0515	0.5	1.5
★1W-0517	0.5	1.7

1W type

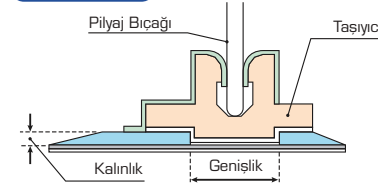

•Uzunluk 700mm
•Pilyaj Bıçağı : 2-3pt(0.7-1.0mm)

W type

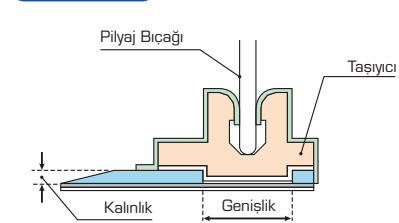

BW type				
Kod	Kalınlık	Genişlik	Merkez Aralığı	Pilyaj Bıçağı
★BW01	0.5	4.5	3.0	2pt (0.7mm)
★BW02	0.5	5.5	4.0	
★BW03	0.5	6.5	5.0	
★BW04	0.6	5.5	3.0	3pt (1.0mm)
★BW05	0.6	6.5	4.0	
★BW06	0.6	7.5	5.0	
★BW07	0.6	8.5	6.0	
★BW08	0.6	9.5	7.0	
★BW09	0.6	10.5	8.0	4pt (1.4mm)
★BW10	0.6	6.0	3.0	
★BW11	0.6	7.0	4.0	
★BW12	0.6	8.0	5.0	
★BW13	0.6	9.0	6.0	
★BW14	0.6	10.0	7.0	
★BW15	0.6	11.0	8.0	

BW type

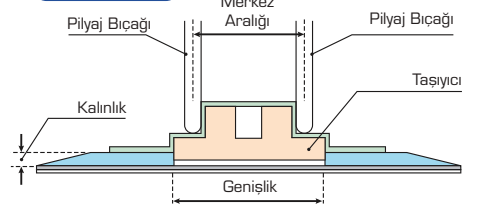

(Çiftli Pilyaj)

•Genişlik 15mm <Genişlik 7.5mm'e kadar>
•Genişlik 20mm <Genişlik 8mm ve daha üstü>
•Uzunluk 700mm

KW type

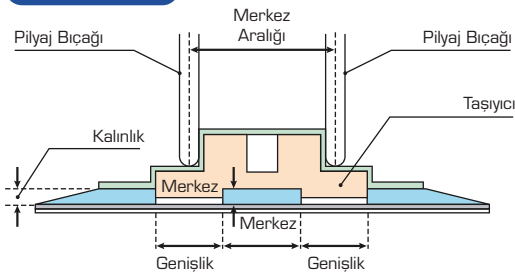

(Çiftli Pilyaj)
•Uzunluk 700mm

SEÇİM TABLOSU

Karton					
Gramaj	Kalınlık	Pilyaj Bıçağı (mm) Kalınlık x Yükseklik	G-TAPE		
			Kod	Kalınlık	Genişlik
50g	0.063-0.065	2pt(0.7) x 23.7	A-0308	0.3	0.8
180g	0.22-0.23	2pt(0.7) x 23.6	A-0410	0.4	1.0
200g	0.26-0.27	2pt(0.7) x 23.6	A-0412	0.4	1.2
230g	0.29-0.30	2pt(0.7) x 23.6	A-0413	0.4	1.3
270g	0.34-0.35	2pt(0.7) x 23.6	A-0414	0.4	1.4
300g	0.39-0.40	2pt(0.7) x 23.5	A-0515	0.5	1.5
350g	0.44-0.46	2pt(0.7) x 23.5	A-0516	0.5	1.6
		3pt(1.0) x 23.5	A-0519	0.5	1.9
400g	0.50-0.52	2pt(0.7) x 23.4	A-0517	0.5	1.7
		3pt(1.0) x 23.4	A-0520	0.5	2.0
450g	0.57-0.59	2pt(0.7) x 23.4	A-0519	0.5	1.9
		3pt(1.0) x 23.4	A-0522	0.5	2.2
500g	0.63-0.65	2pt(0.7) x 23.4	A-0520	0.5	2.0
		3pt(1.0) x 23.4	A-0522	0.5	2.2
550g	0.70-0.72	3pt(1.0) x 23.3	A-0624	0.6	2.4
		4pt(1.4) x 23.3	B-0627	0.6	2.7
600g	0.76-0.78	3pt(1.0) x 23.2	A-0825	0.8	2.5
		4pt(1.4) x 23.2	B-0830	0.8	3.0

Oluklu Mukavva

Pilyaj Bıçağı		3pt(1.0) Kalınlık		4pt(1.4) Kalınlık		6pt(2.0) Kalınlık		8pt(3.0) Kalınlık	
Dalga		Kod	Kalınlık x Genişlik	Kod	Kalınlık x Genişlik	Kod	Kalınlık x Genişlik	Kod	Kalınlık x Genişlik
E/F	Sheet	S-0627	0.6x2.7	B-0630	0.6x3.0	C-0835	0.8x3.5	-	-
	Lining board	S-0630	0.6x3.0	B-0632	0.6x3.2	C-0835	0.8x3.5	-	-
B/F	Sheet	S-0830	0.8x3.0	B-0835	0.8x3.5	C-0840	0.8x4.0	D-0850	0.8x5.0
	Lining board	S-0830	0.8x3.0	B-0835	0.8x3.5	C-0840	0.8x4.0	D-0850	0.8x5.0
A/F	Sheet	-	-	B-0840	0.8x4.0	C-1050	1.0x5.0	D-1060	1.0x6.0
AB/F	Sheet	-	-	B-1050	1.0x5.0	C-1060	1.0x6.0	D-1070	1.0x7.0

Bıçak Kalınlık Tablosu

Pilyaj Bıçağı		3pt(1.0) Kalınlık		4pt(1.4) Kalınlık		6pt(2.0) Kalınlık		Punto	mm
Dalga		Kod	Kalınlık x Genişlik	Kod	Kalınlık x Genişlik	Kod	Kalınlık x Genişlik		
E/F	Sheet	A-0624	0.6x2.4	B-0627	0.6x2.7	C-0832	0.8x3.2	1pt	0.35
	Lining board	A-0825	0.8x2.5	B-0830	0.8x3.0	C-0835	0.8x3.5	1.5pt	0.45
								2pt	0.7
								3pt	1.0
								4pt	1.4
								6pt	2.0
								8pt	3.0

G-TAPE Ölçü Belirleme Yöntemi

Karton

* Kalınlık G-TAPE =
Bıçak yüksekliği - Pilyaj Bıçağı Yüksekliği
* Pilyaj Genişliği = Karton Kalınlığı x 2 +
Pilyaj Bıçağı Kalınlığı

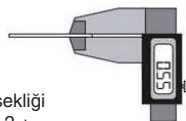

Oluklu Mukavva

* Kalınlık G-TAPE =
Oluklu Mukavva Sıkıştırılmış Kalınlık
* Pilyaj Genişliği =
Sıkıştırılmış Kalınlık x 2.2 + Pilyaj Bıçağı Kalınlığı

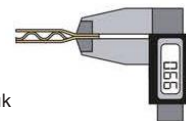

VS-IV DAISO HAZIR OLUK MAKASI



Kenar Kesim Gerektirmez

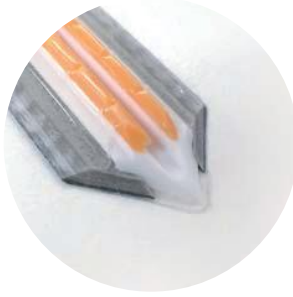

Daiso hazır oluk makası V kesim ve açılı kenar kesimi aynı anda yapar. Hazırlık sürecini azaltır. Bütün kesimler standart olur. Uluslararası patentlidir. Standart kesim uzunluğu 50cm 'dir.

VS-IV Özellikler

- Uzunluk / 740mm
- Genişlik / 90mm
- Yükseklik / 310mm
- Ağırlık / 6.8Kg.

ÜRETİM SİMÜLASYONU

Kenar traşlama 20 dakika zaman alır.



5 kez yapıldığında 75-100 dakika süre olur



VS-IV makas kullanıldığında aylık 30-40 saat avantaj sağlar.



Plaka üzerinde traşlama yapılmayacağı için atıklar olmayacak, kesim yapılmayacağı için plaka temiz kalacak

PRATİK AYIKLAMA BIÇAĞI

15mm Kontrplak için
100/50/30mm



18mm Kontrplak için
100/50/30mm



Bıçak kalıbı hazırlandıktan sonra pratik ayıklama bıçağı kalıp üzerine yapıştırılır. Lazer kesim yapmadan tek dokunuşla sorun çözülür. Kendinden yapışkanlıdır.

NASIL KULLANILIR?



Ürün	Uzunluk	Ölçü	Renk
Ayıklama Bıçağı 18-30	30	Kontrplak 18mm	Yeşil
Ayıklama Bıçağı 18-50	50	Kontrplak 18mm	Yeşil
Ayıklama Bıçağı 18-100	100	Kontrplak 18mm	Yeşil
Ayıklama Bıçağı 15-30	30	Kontrplak 15mm	Turuncu

DAISO BIÇAK BİLEME



YENİ

ESKİ

BİLENMİŞ



Daiso Bıçak Bileme Aparatı

- 1- Kağıt tozunu azaltır
- 2- Bıçağı keskinleştirir
- 3- Kalıbın kalıpcıya gitmesine gerek kalmaz
- 4- Pası temizler

NASIL KULLANILIR?

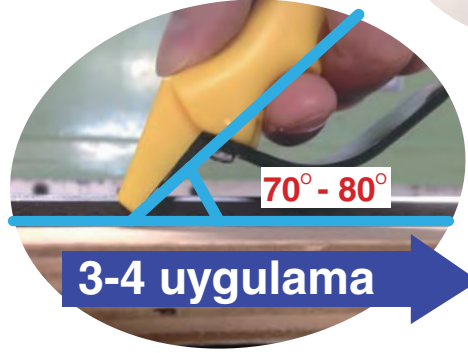

70° - 80°

3-4 uygulama

JUMPING STICKER

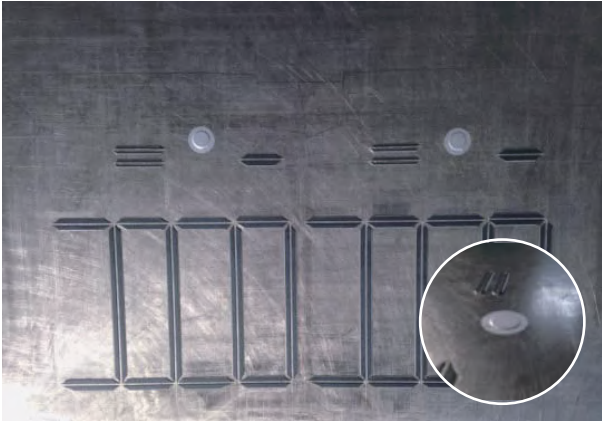

Kesilen malzemenin plakadan kolay ayrılmasını sağlar.

NASIL KULLANILIR?

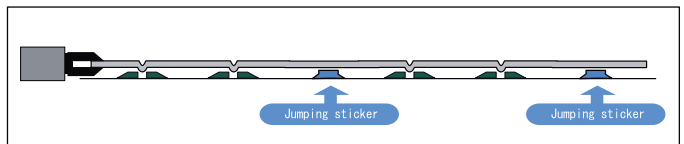
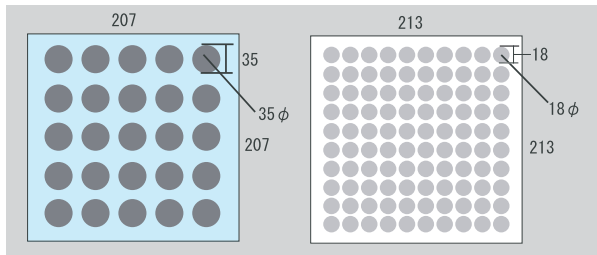
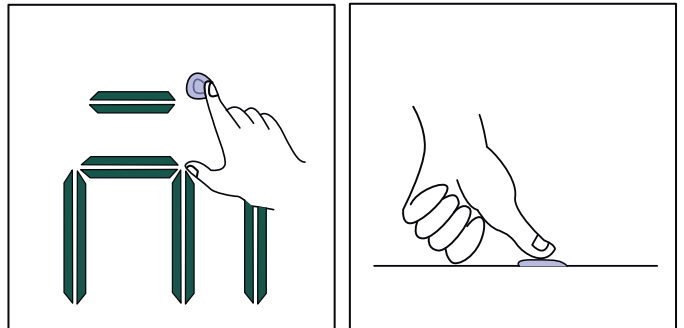

SUPER-G GLUE HIZLI YAPIŖTIRICI



Yüzeylere çok iyi yerleşir,
kuvvetli yapıştırır.

Hızlı kuruma özelliđi ile
kesim öncesi zamanı
kısaltır.

Ekonomiktir.

Hazır Oluk / Karton yapıştırıcısı



G-Tape



Cutting Paper



Counter Plate

Ürün	Özellik
Super-G	50g / Şişe

CYANON GLUE HIZLI YAPIŖTIRICI



Profil lastikleri ve mantar yapıştırıcısı

Ürün	Özellik
Cyanon 20g	20g / Şişe
Cyanon 50g	50g / Şişe

AUTO-NICK PUNCH OTOMATİK NİK ATMA APARATI



Nik atma aparatı
Standart ölçülerde pratik ve düzgün nik atar.

Ürün	Ölçü	Renk
Auto-Nick-Punch	0.3	Black
Auto-Nick-Punch	0.5	Green
Auto-Nick-Punch Δ	Δ Triangle	Red

PERTİNAKS MONTAJ MALZEMELERİ

G-SETTER



Pertinaks montaj malzemeleri



Ürün	Özellik
G-setter Box	Case and pliers
G-setter Cover	Plastic cover (yellow)
G-setter Pin	Brass pin
G-setter Rubber	Urethane sponge (gree)

SET PIECE

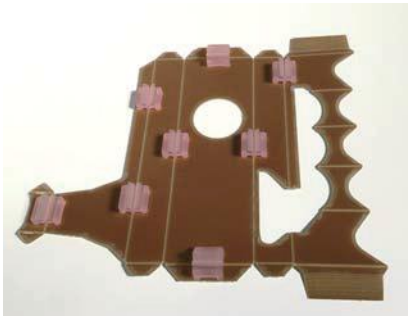

Pertinaks montaj malzemeleri

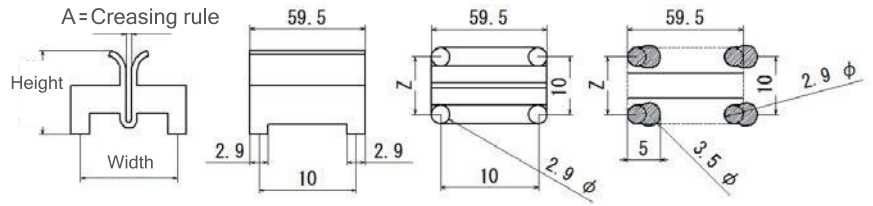

Ürün	Pilyaj Bıçağı	Genişlik x Yükseklik
Set Piece	2-3pt	12.9 x 8

DAISO LOCATOR

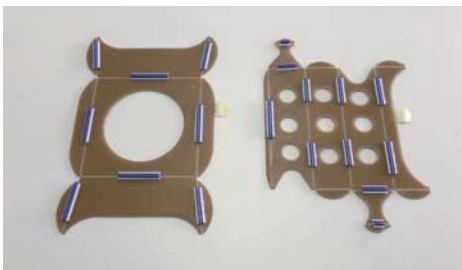

Pertinaks montaj malzemeleri

Ürün	Pilyaj Bıçağı
DAISO locator	2-3pt

DAISO MAT

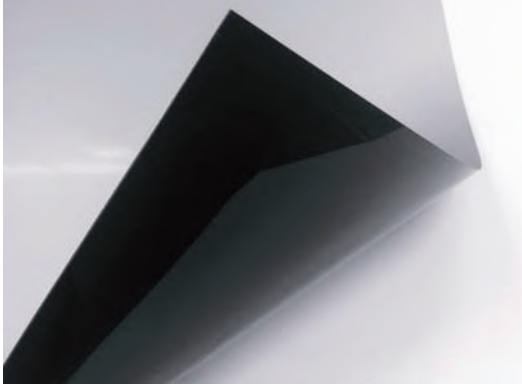

Hazırlık zamanını kısaltır
Mizantren uygulamasını en aza indirir veya gerektirmez.
Bıçak ağızlarını korur. Kağıt tozunu azaltır.

Name	Yükseklik x Genişlik x Uzunluk
DAISO MAT 720x1020	0.5 x 720 x 1020
DAISO MAT 740x1060	0.5 x 740 x 1060
DAISO MAT 930x1300	0.5 x 930 x 1300

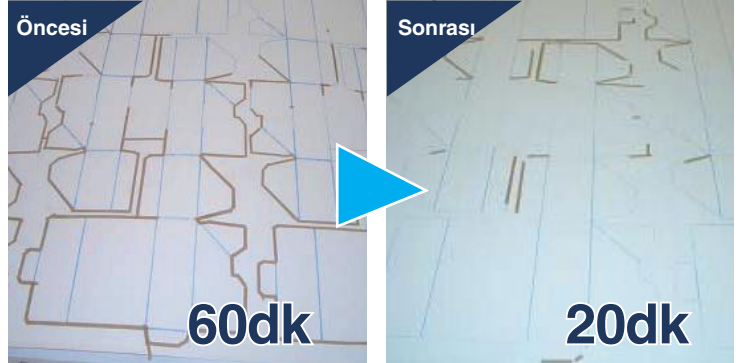
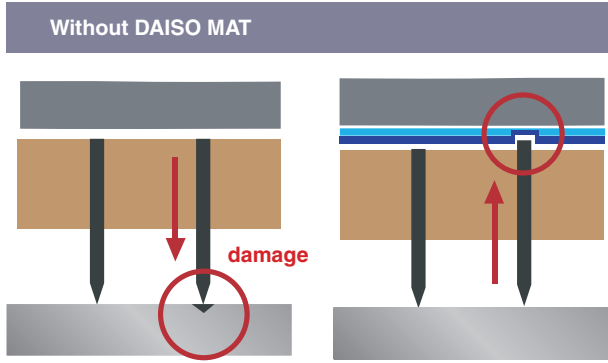

NASIL KULLANILIR?

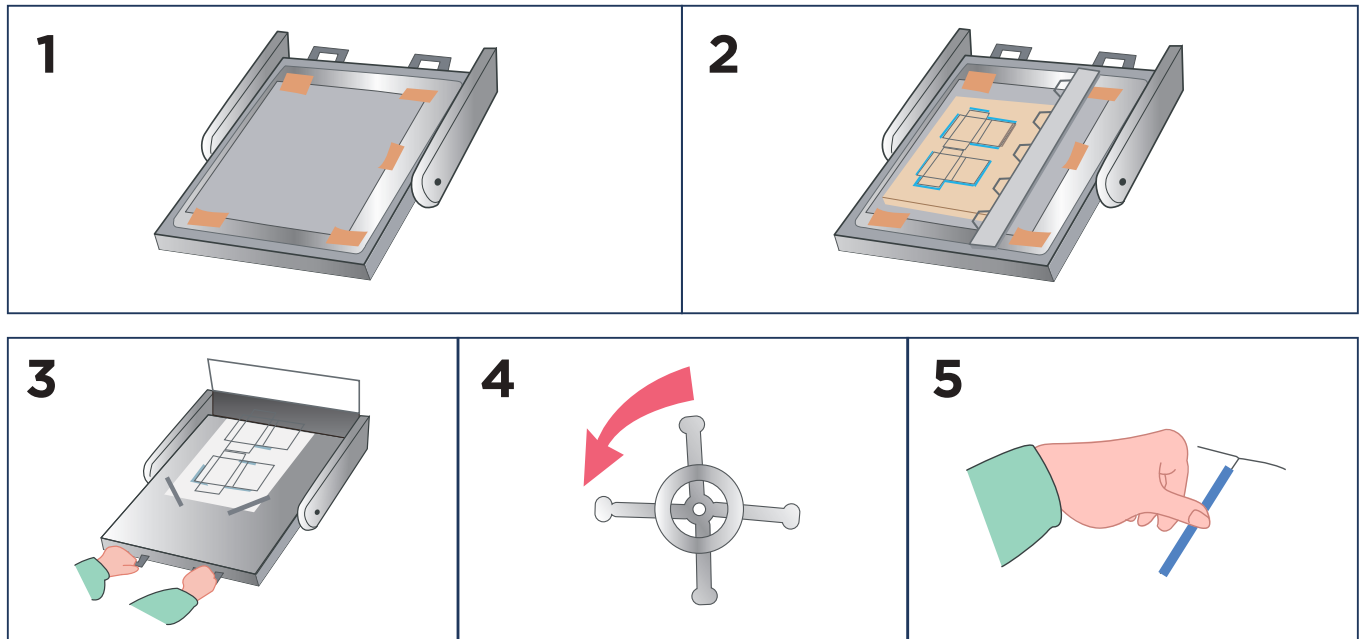

MİZANTREN BANTLARI

KAĞIT BAZLI



BLUE TAPE

0.09 mm x 6 mm x 6 m



WHITE TAPE

0.14 mm x 6 mm x 5 m
0.19 mm x 6 mm x 5 m



NOMEX TAPE

0.09 mm x 6 mm x 50 m
0.09 mm x 12 mm x 50 m



FLAT TAPE

0.15 mm x 6 mm x 30 m

KAĞIT/PLASTİK BAZLI

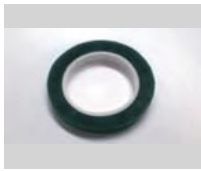

SYSTEM TAPE GREEN

0.02 mm x 3 mm x 25 m
0.02 mm x 6 mm x 25 m



SYSTEM TAPE RED

0.06 mm x 3 mm x 25 m
0.06 mm x 6 mm x 25 m
0.06 mm x 12 mm x 25 m



SYSTEM TAPE BLUE

0.04 mm x 3 mm x 35 m
0.04 mm x 6 mm x 35 m
0.04 mm x 12 mm x 35 m

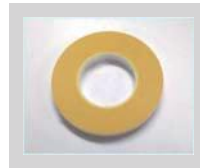

SYSTEM TAPE YELLOW

0.08 mm x 3 mm x 18 m
0.08 mm x 6 mm x 18 m
0.08 mm x 12 mm x 18 m

ÇELİK BAZLI



RIBBON TAPE

0.03 mm x 8 mm x 20 m
0.05 mm x 8 mm x 20 m
0.10 mm x 8 mm x 15 m



ALÜMİNYUM BAZLI



LIBIC TAPE

0.06 mm x 6 mm x 10 m
0.06 mm x 9 mm x 10 m
0.06 mm x 12 mm x 10 m
0.06 mm x 15 mm x 10 m





DAISO
TOTAL PLANNING

grensan®

**Grensan Matbaa Malzemeleri
San. ve Tic. Ltd. Şti.**

Bağlar Mah. Yalçın Koreş Cad.
Erna Sit. No:16/2 34209 Bağcılar/İstanbul

**T: +90 212 657 68 00 (Pbx)
F: +90 212 657 78 68**

**grensan@grensan.com.tr
www.grensan.com.tr**